

80UPZM42.9L

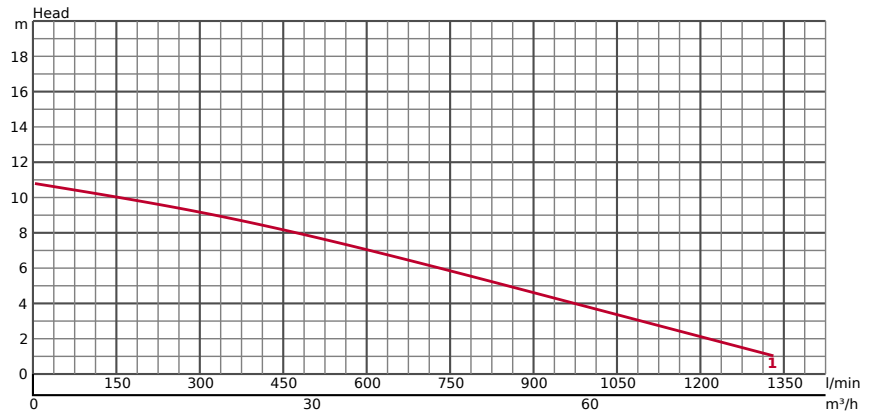

TECHNICAL INFORMATION

GENERAL		PUMPING FLUID	
ø Discharge bore mm	80	Type of Fluid	Sewage
Discharge Connection	Flange DIN/ANSI DN80 (PN10)	Temperature	0-40°C
ATEX available	Yes	Max. Solid Handling mm	80
		Max. PH Value	5-9
		Max. Capacity l/min	1333
		Max. Head m	10.80

PUMP	COMPONENTS	MATERIAL	
Impeller	Vortex impeller	Impeller	Grey iron casting EN-GJL-250
Bearings	Shielded ball bearings	Casing	Grey iron casting EN-GJL-250
Mechanical Seal	Inside/outside mechanical seal		

TECHNICAL INFORMATION | Motor, Others on the next page →

MOTOR	Motor output kW	2,9	MATERIAL	
	Starting method	direct online	Shaft	Stainless steel EN-X14Cr-Mo-S17
	Type, Poles	Induction motor, 4 poles, IP68	Cable	H07RN8-F PLUS 10G1, 5
	Insulation	Insulation class H	Cable Length	10m
	Phase / Voltage	3-phase / 400V / 50Hz		
	r.p.m.	1450		
	Motor Protector (built-in)	Miniature protector		
	Rated Current	5,9		

OTHERS	Dry Weight Kg	116.25
	Pressure Resistance	max. 20m

DIMENSIONS

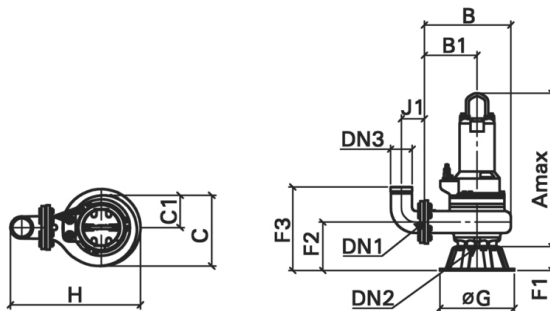

DIMENSIONS - IN MM					
A	722	C1	158	G	395
B	408	DN1	80	H	628
B1	250	DN2	100	J1	137
C	316	DN3	80		

DIMENSIONS | GUIDE RAIL FITTING TYPE

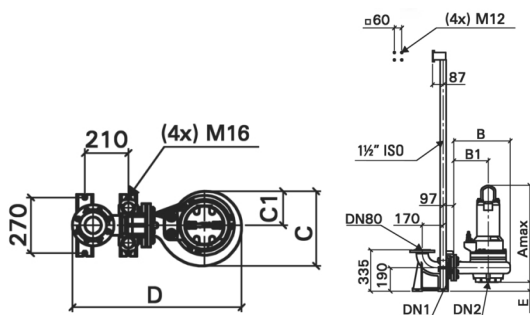

DIMENSIONS GUIDE RAIL FITTING TYPE - IN MM					
A	722	C	316	DN1	80
B	408	C1	158	DN2	100
B1	250	D	775	E	112

PERFORMANCE CURVE

