

100C42.2

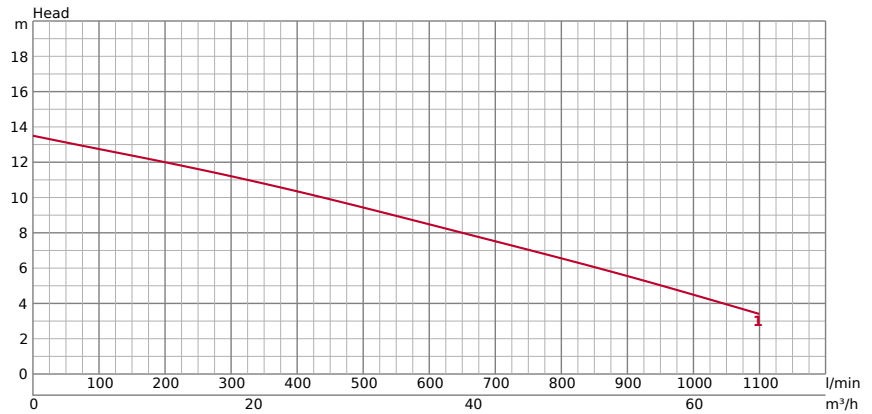

TECHNICAL INFORMATION

GENERAL

∅ Discharge bore mm	100mm
Discharge Connection	Inside thread, JIS10K flange

PUMPING FLUID

Type of Fluid	Sewage
Temperature	0-40°C
Max. Solid Handling mm	67 x 56
Max. PH Value	5-9
Max. Capacity l/min	1100
Max. Head m	13.50

TECHNICAL INFORMATION | Pump, Motor, Others on the next page →

PUMP	COMPONENTS		MATERIAL	
	Impeller	Non-clog impeller with cutter mechanism	Impeller	Grey iron casting EN-GJL-200 with sintered tungsten carbide alloy tip
	Bearings	Shielded ball bearings	Casing	Grey iron casting EN-GJL-200
	Mechanical Seal	Dual mechanical seal in oil bath	Suction Plate	Ductile iron casting EN-GJS-700-2
		Pump Body	Grey iron casting EN-GJL-150	
		Mechanical Seal	Silicon Carbide	

MOTOR			MATERIAL	
	Motor output kW	2,2	Frame	Grey iron casting EN-GJL-150
	Starting method	direct online	Shaft	Stainless steel EN-X30Cr13
	Suitable for VFD	Yes	Cable	NSSHÖU 4C*1.5mm ²
	Suitable for Soft Starter	Yes	Cable Length	10m
	Type, Poles	Induction motor, 4 poles, IP68		
	Insulation	Insulation class E		
	Phase / Voltage	3-phase / 400V / 50Hz		
	r.p.m.	1420		
	Motor Protector (built-in)	Circle thermal cut-out		
Rated Current	5			

OTHERS		
Dry Weight Kg	70	
Pressure Resistance	max. 30m	

DIMENSIONS

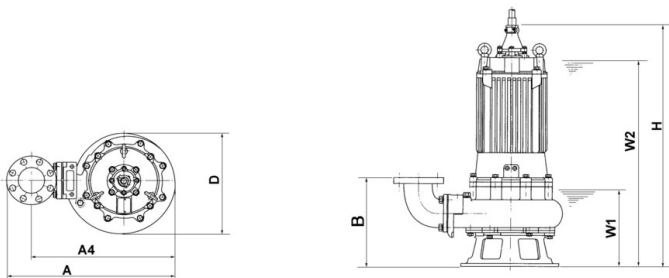
DIMENSIONS - IN MM

A	594	D	324	W1	225
A4	489	H	616	W2	570
B	328				

DIMENSIONS | GUIDE RAIL FITTING TYPE

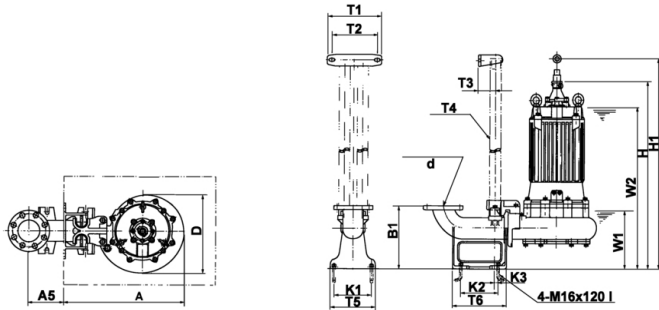

DIMENSIONS | GUIDE RAIL FITTING TYPE - IN MM

A	484	H	631	W1	240
A5	165	H1	790	W2	585
D	324				

PERFORMANCE CURVE

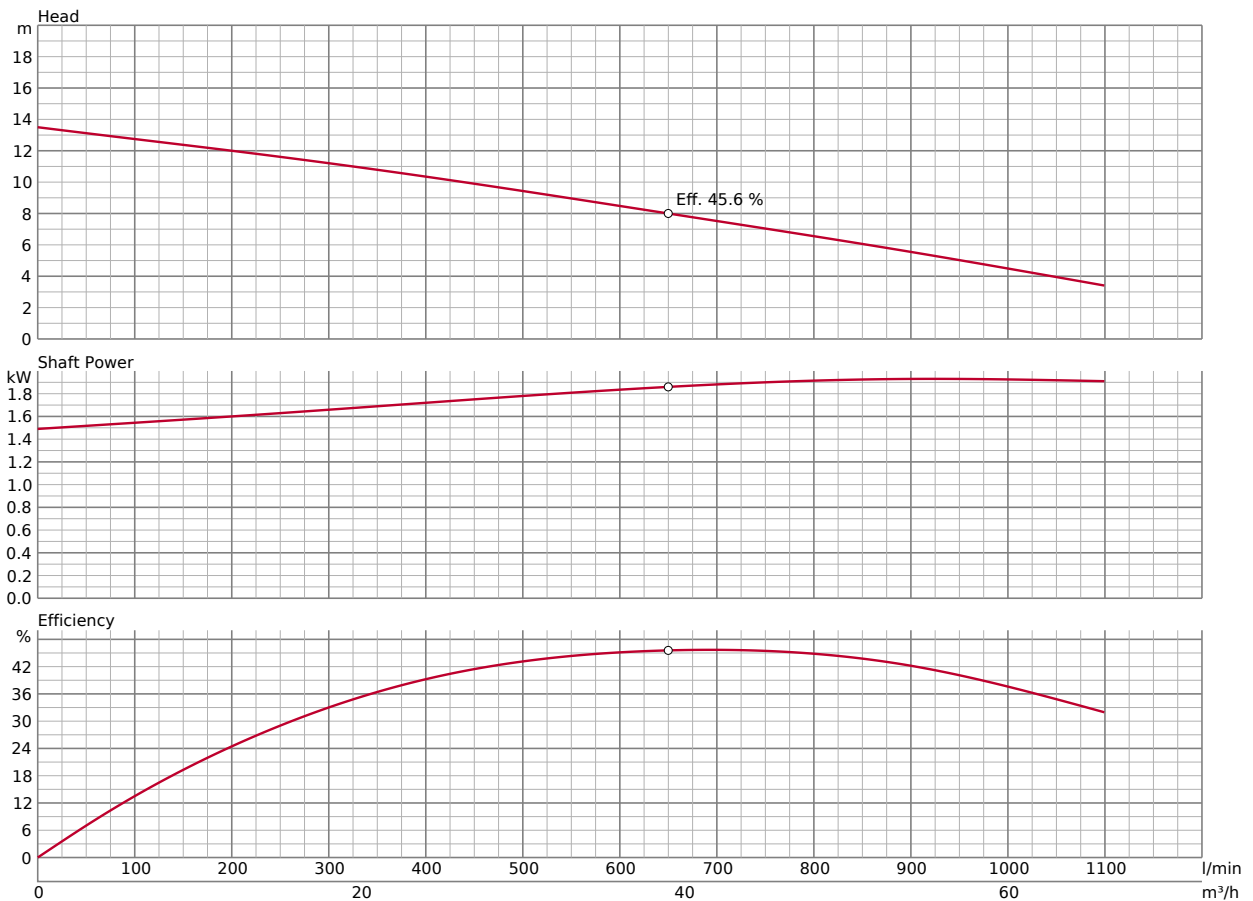

Please mind: discharge bend, duck foot bend and stand set are accessories and must be ordered separately

ACCESSORIES

OIL LEAKAGE SENSOR **TSS-TEG-10**

TSS Seal Oil Sensor M10 (10m)

Externally mounted leak sensors for water detection inside of oil chamber. Please note, an additional relay e.g. finder needs to be installed.



FLOAT SWITCH **106-TEG-03**

Float 10m (for Sewage Pumps) up to 2.2kW

Automatic Operation: Activates the submersible pump when water levels rise to a preset height and deactivates it when levels drop, preventing overflow or pump damage.



FREE STAND INSTALLATION KIT **(U)XIBEND4T**

BEND 80-100

Discharge/elbow for vertical pumping



ACCESSORIES

GUIDE RAIL FITTING SYSTEM (U)XITOS381TA TOS3-80-100

TOS is the basic guide-rail fitting system for Tsurumi pumps up 150mm discharge bore.

