

80C21.5

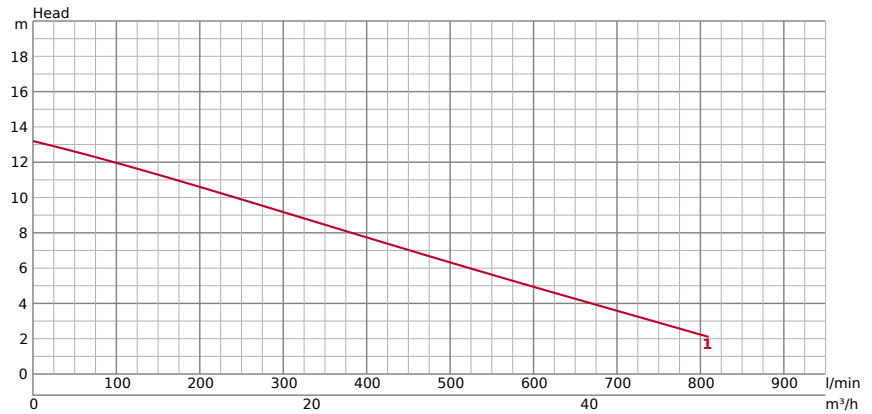

TECHNICAL INFORMATION

GENERAL		PUMPING FLUID	
Ø Discharge bore mm	80mm	Type of Fluid	Sewage
Discharge Connection	Inside thread, JIS10K flange	Temperature	0-40°C
		Max. Solid Handling mm	43 x 60
		Max. PH Value	5-9
		Max. Capacity l/min	810
		Max. Head m	13.20

TECHNICAL INFORMATION | Pump, Motor, Others on the next page →

PUMP	COMPONENTS		MATERIAL	
	Impeller	Non-clog impeller with cutter mechanism	Impeller	Grey iron casting EN-GJL-200 with sintered tungsten carbide alloy tip
	Bearings	Shielded ball bearings	Casing	Grey iron casting EN-GJL-200
	Mechanical Seal	Dual mechanical seal in oil bath	Suction Plate	Ductile iron casting EN-GJS-700-2
		Pump Body	Grey iron casting EN-GJL-150	
		Mechanical Seal	Silicon Carbide	

MOTOR			MATERIAL	
	Motor output kW	1,5	Frame	Grey iron casting EN-GJL-150
	Starting method	direct online	Shaft	Stainless steel EN-X30Cr13
	Suitable for VFD	Yes	Cable	NSSHÖU 4C*1.5mm ²
	Suitable for Soft Starter	Yes	Cable Length	10m
	Type, Poles	Induction motor, 2 poles, IP68		
	Insulation	Insulation class E		
	Phase / Voltage	3-phase / 400V / 50Hz		
	r.p.m.	2912		
	Motor Protector (built-in)	Circle thermal cut-out		
Rated Current	3.60			

OTHERS		
Dry Weight Kg	36	
Pressure Resistance	max. 30m	

DIMENSIONS

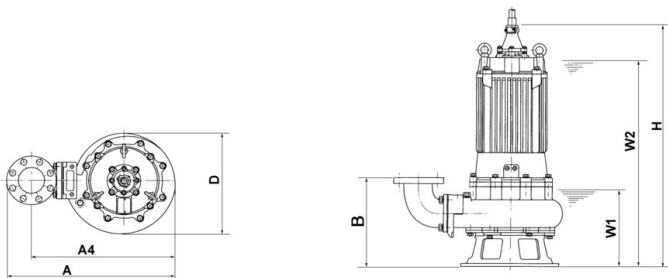

DIMENSIONS - IN MM					
A	446	D	250	W1	190
A4	392	H	536	W2	465
B	234				

DIMENSIONS | GUIDE RAIL FITTING TYPE

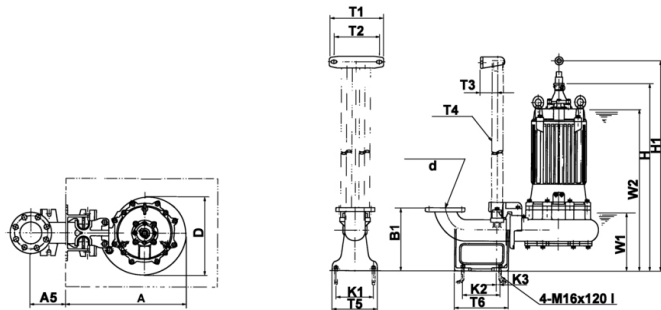

DIMENSIONS | GUIDE RAIL FITTING TYPE - IN MM

A	410	D	250	W1	240
A5	165	H	586	W2	515

PERFORMANCE CURVE

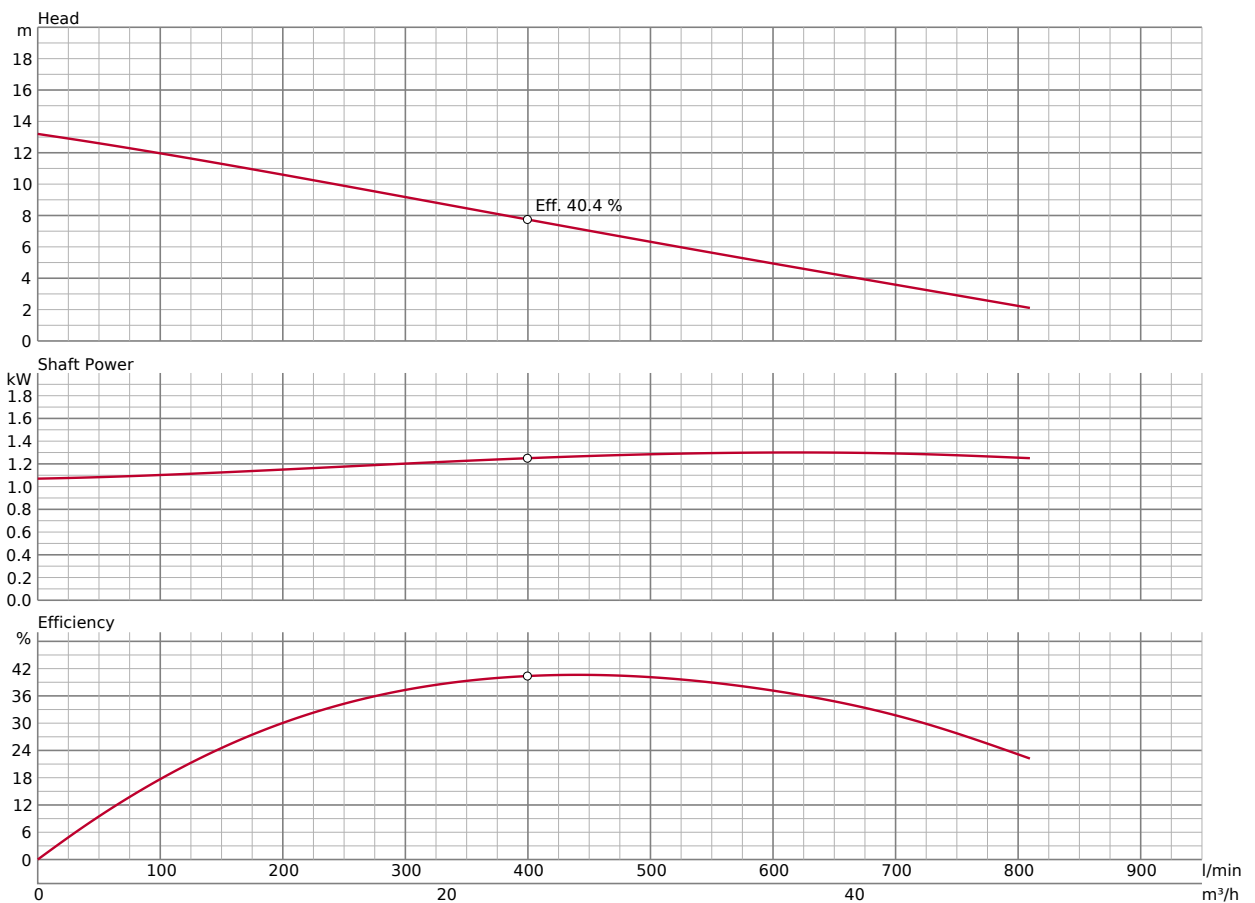

Please mind: discharge bend, duck foot bend and stand set are accessories and must be ordered separately

ACCESSORIES

PUMP DISCHARGE **048-105-17**

3" Special Screwed Flange

3" special flange 65mm / inside thread

OIL LEAKAGE SENSOR **TSS-TEG-08**

TSS Seal Oil Sensor M8 (10m)

Externally mounted leak sensors for water detection inside of oil chamber. Please note, an additional relay e.g. finder needs to be installed.



FLOAT SWITCH **106-TEG-03**

Float 10m (for Sewage Pumps) up to 2.2kW

Automatic Operation: Activates the submersible pump when water levels rise to a preset height and deactivates it when levels drop, preventing overflow or pump damage.



ACCESSORIES

MOTOR PROTECTION PLUGS **547150403tu**

Plug CEE 16A

SPECIFICATIONS

Amperage Control	2,5A - 4,0A	IP	44
Cable Gland	M25		

Rotary lever actuation, motor protection with adjustment of the respective rated current, with phase turner and rotary field control, cable gland, Overload Protection: Automatically disconnects the motor in case of excessive current draw, preventing over



MOTOR PROTECTION PLUGS **547250403tu**

Plug CEE 32 A

SPECIFICATIONS

Amperage Control	2,5A - 4,0A	IP	44
Cable Gland	M32		

Rotary lever actuation, motor protection with adjustment of the respective rated current, with phase turner and rotary field control, cable gland, Overload Protection: Automatically disconnects the motor in case of excessive current draw, preventing over



FREE STAND INSTALLATION KIT **(U)XIBEND3T**

BEND 80

Discharge/elbow for vertical pumping



ACCESSORIES

GUIDE RAIL FITTING SYSTEM (U)XITOS380TA TOS3-80-80

TOS is the basic guide-rail fitting system for Tsurumi pumps up 150mm discharge bore.



CABLE REPAIR SET 061-TEG-06

Cable Repair Kit for 001-TEG-31 Cabtyre Cable Set (20m) H07RN-F4Cx1,5mm² and M01-TEG-31 Cable NSSHOEU 4G*1,5 mm² (20m)

Cable repair set which allows you to repair a broken cable on site by yourself.

